



Two-Door Ice Box

Plan No. 686

Copyright U-Build, Inc., 2003.
All rights reserved. Printed in the U.S.A.

Although refrigerators long ago rendered them obsolete, antique oak ice boxes remain popular with collectors, even though they're expensive and hard to find.

This do-it-yourself version is neither: it's both inexpensive and easy to build. An authentic reproduction of an original, the project is especially popular when used as a bar, but it has many other uses. The top opens up to reveal a convenient storage area, and the lower cabinet features two compartments perfect for glassware and other fragile items.

The ice box measures 38 inches high by 24 inches wide by 16 inches deep.

Bill of Material

Quantity	Size	Material
10	3/4" x 6" x 96"*	oak
1	1/8" x 48" x 48"	oak plywood
60	3/8" x 2"	dowels
1 small box	1 1/4"	finish nails
1 small bottle		wood glue
1 small can		oil or stain
6		brass ice box hinges
2		brass ice box handles
1		brass top lid handle

*approximately 40 board feet

NOTES

1. Read all instructions and check materials before beginning work.
2. Read manufacturer's instructions before operating equipment.
3. Oak is preferred for this project.
4. Edge-gluing is required to achieve the necessary width of boards F, H, N, X, AA and EE.
5. When using finish nails on oak, drill pilot holes to avoid splitting.
6. **Always** wear safety glasses.

Cutting Schedule

Item	Qty	T	W	L	Material	Item	Qty	T	W	L	Material
A	2	3/4"	3"	35 1/4"	oak	Q	2	3/4"	4"	16 3/4"	oak
B	2	3/4"	2 1/4"	35 1/4"	oak	R	1	3/4"	4"	25 1/2"	oak
C	2	3/4"	3"	10"	oak	S	1	1/8"	23 1/4"	37 1/4"	oak plywood
D	2	3/4"	2"	10"	oak	T	2	3/4"	2"	12 3/4"	oak
E	2	3/4"	4"	10"	oak	U	2	3/4"	2"	25 1/2"	oak
F	2	3/4"	10"	11 1/4"	oak	V	2	3/8"	3/4"	16 3/8"	oak
G	2	1/8"	10 1/2"	11 3/4"	oak plywood	W	1	3/8"	3/4"	24 3/4"	oak
H	2	3/4"	10"	15"	oak	X	1	3/4"	13 3/8"	22 1/8"	oak
I	2	1/8"	10 1/2"	15 1/2"	oak plywood	Y	2	3/4"	2"	14 5/8"	oak
J	2	3/4"	3"	35 1/4"	oak	Z	2	3/4"	2"	11 7/8"	oak
K	1	3/4"	3"	18"	oak	AA	1	3/4"	7 7/8"	14 5/8"	oak
L	1	3/4"	2"	18"	oak	BB	1	1/8"	8 3/8"	15 1/8"	oak plywood
M	1	3/4"	4"	18"	oak	CC	2	3/4"	2"	14 5/8"	oak
N	3	3/4"	15 1/8"	22 1/2"	oak	DD	2	3/4"	2"	15 5/8"	oak
O	1	3/4"	2 1/4"	22 1/2"	oak	EE	1	3/4"	11 5/8"	14 5/8"	oak
P	1	3/4"	2"	24"	oak	FF	1	1/8"	12 1/8"	15 1/8"	oak plywood

Isometric

Note that Parts G, P and BB do not appear on this drawing.

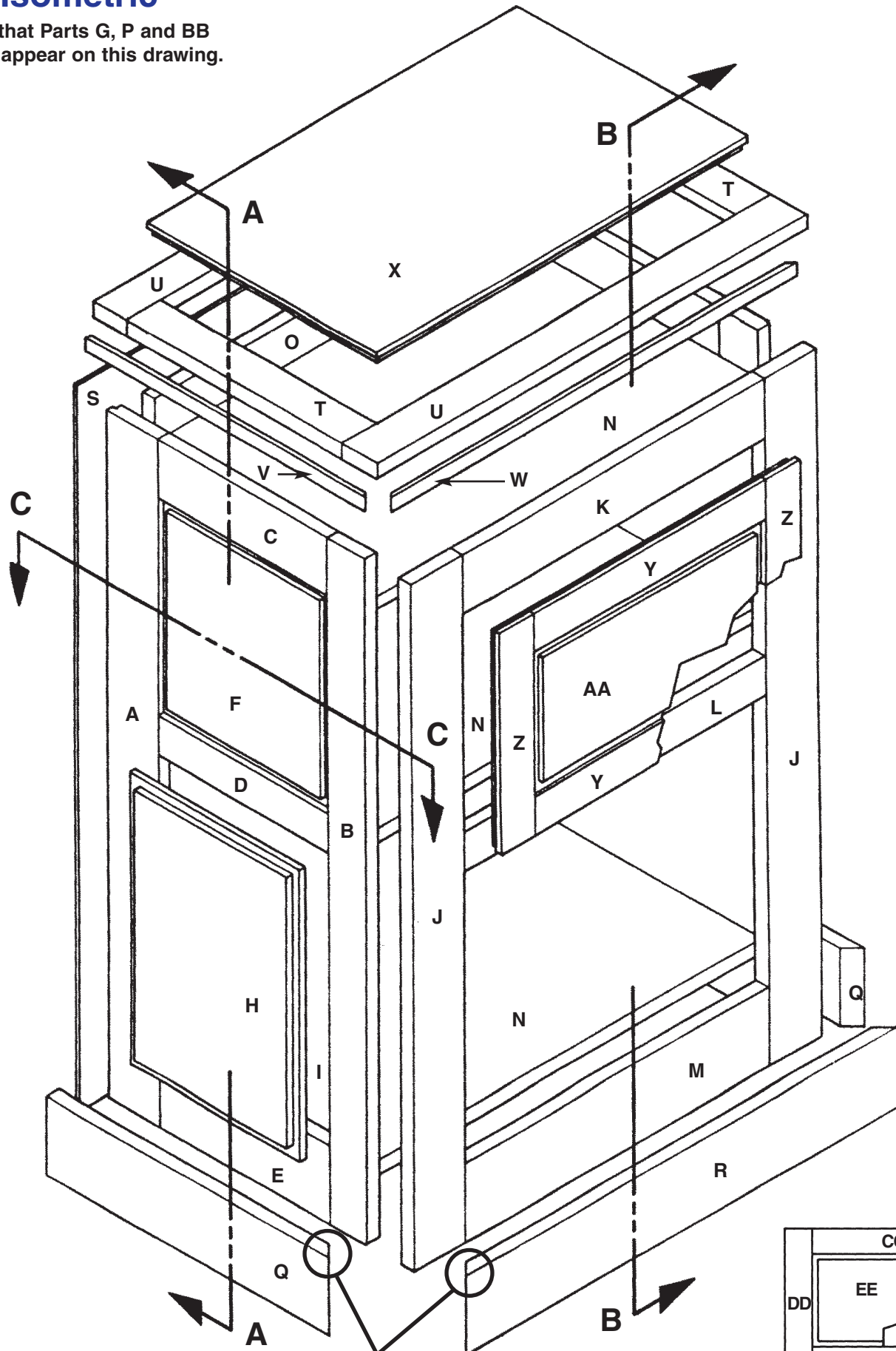

45 DEGREE
MITER CUT.

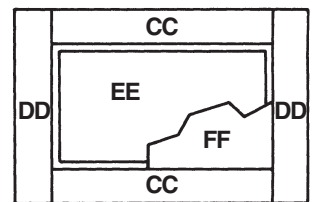

Lower Door

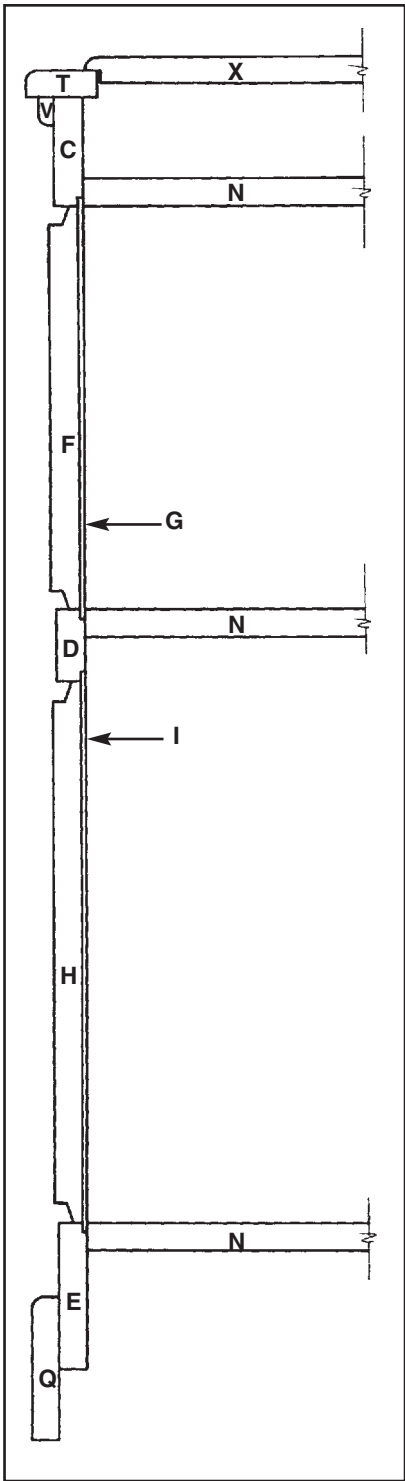

Section A-A

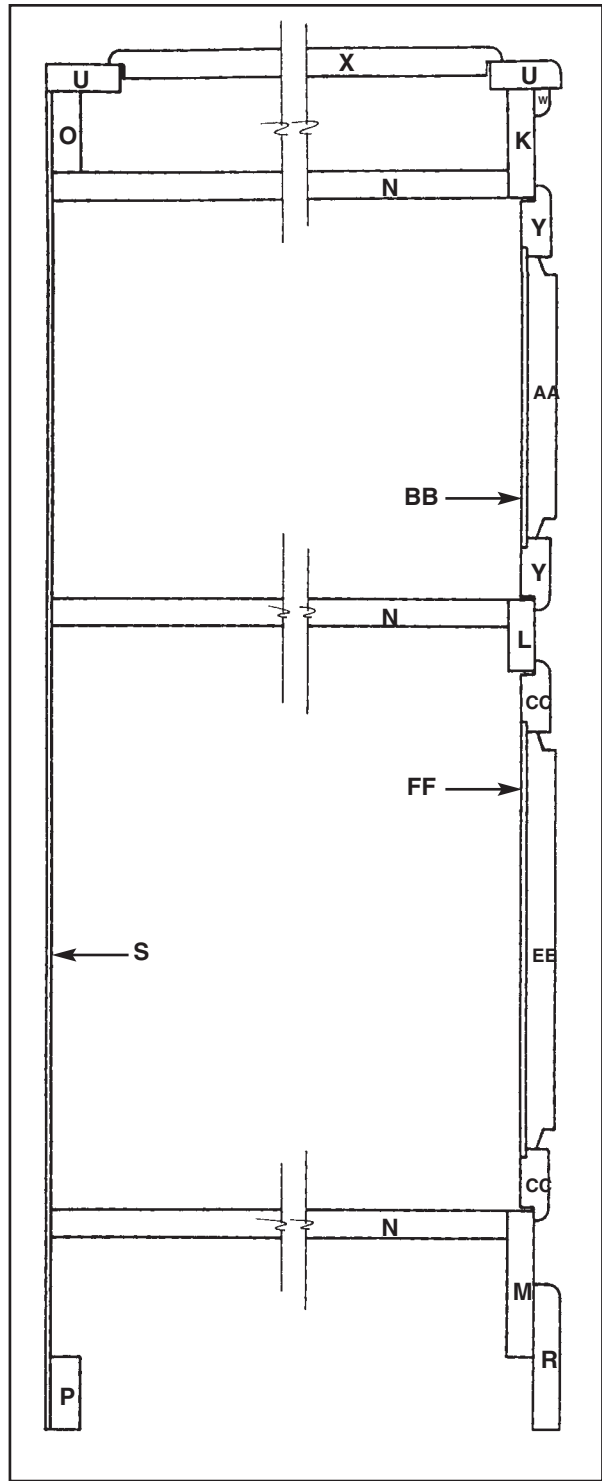

Section B-B

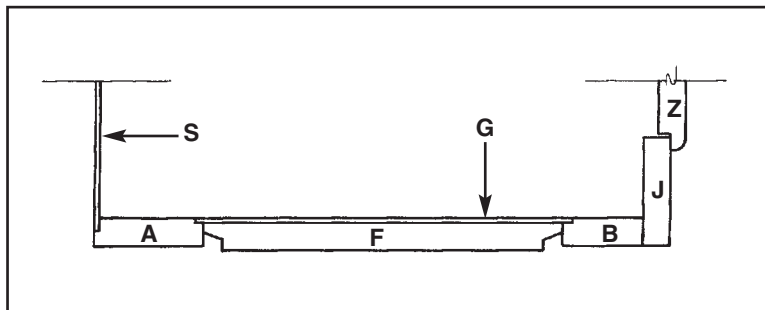

Section C-C

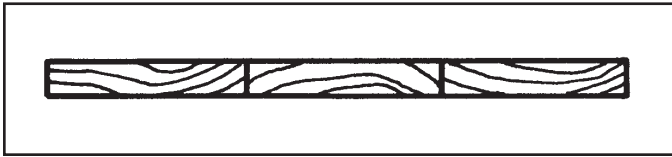

Figure 1
End View of Top Lid X
Showing Annular Rings Reversed

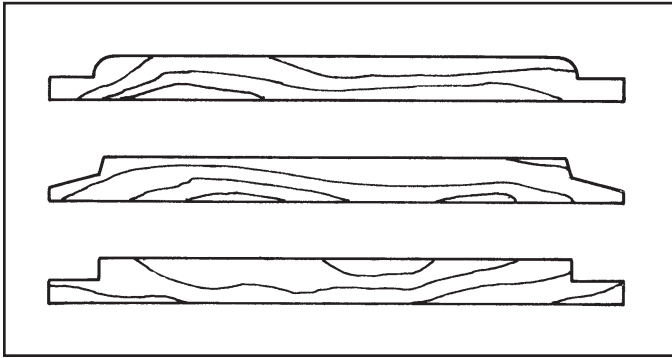

Figure 3
Optional Decorative Cuts
for Raised Center Panels

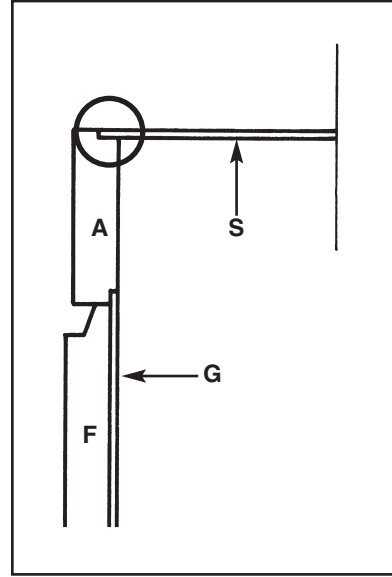
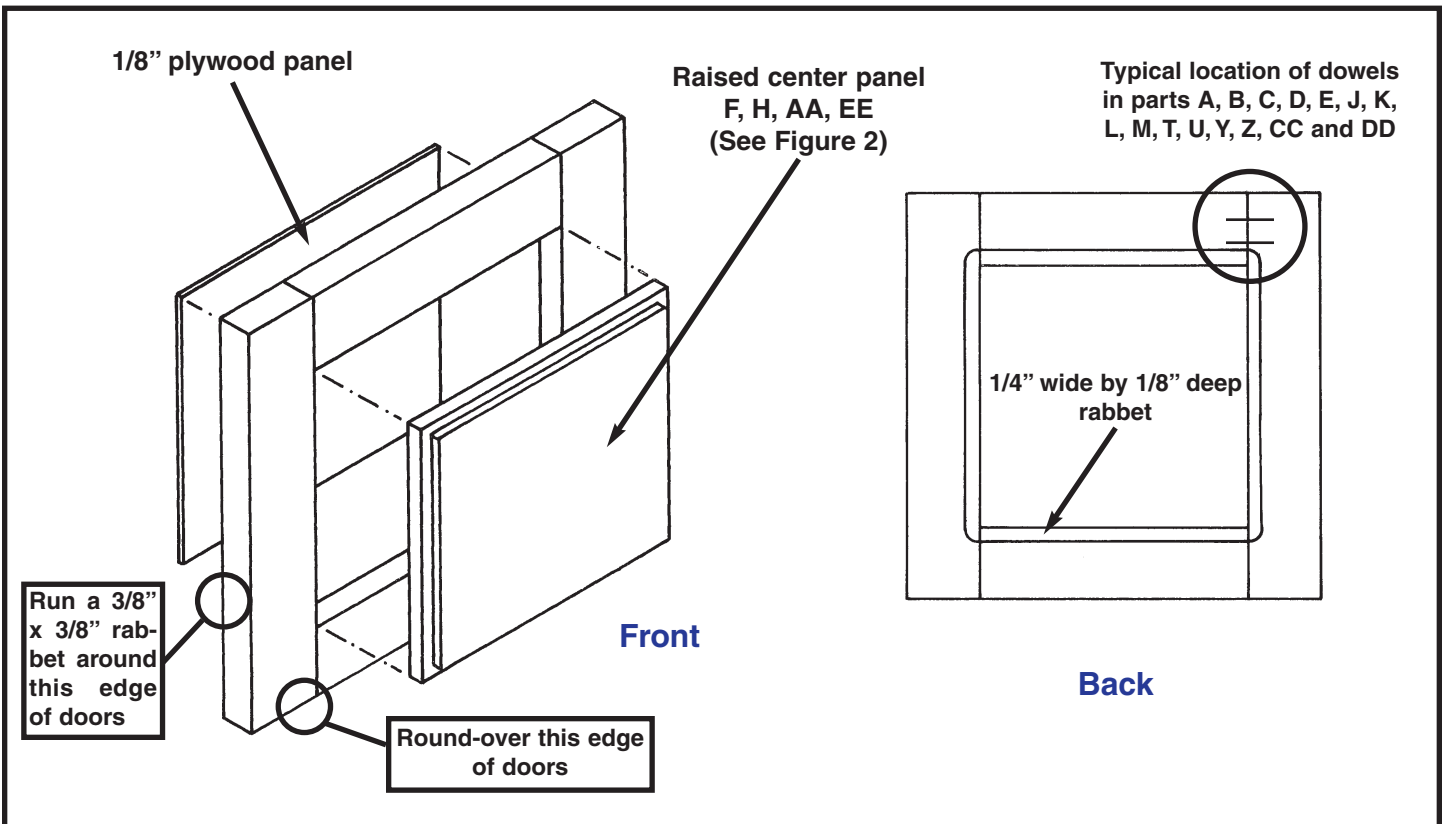

Figure 2



Detail 1
Door & Side Panel Construction

Assembly Instructions

Read all instructions before beginning any work. Cut all material to sizes shown in cutting schedule.

1. Construct top lid X using three pieces of lumber, reversing direction of the grain and gluing and clamping (this will minimize warping). See Figure 1. Allow glue-up to dry thoroughly.
2. Round-over all four top edges and run a 3/8" x 3/8" rabbet around all four bottom edges of board X. See Sections A-A and B-B.
3. Mark location for dowels in pieces A, B, C, D, E, J, K, L, M, T, U, Y, Z, CC and DD and drill 3/8" holes for dowels. Refer to Detail 1.
4. Assemble and clamp face frame, side frames and door frames using 3/8" dowels and wood glue. Check for squareness. Refer to Isometric.
5. Rout a 1/4" wide by 1/8" deep rabbet around the inside edges of the openings in side panels and door frames to accommodate 1/8" plywood. See Sections A-A, B-B and C-C and Detail 1.
6. Cut a 1/8" deep by 3/8" wide rabbet inside back edge of side panel frames. See Figure 2.
7. Glue 1/8" plywood panels to inside side and door frames (do not use nails). See Detail 1.
8. Using your router, create raised center panels F, H, AA and EE. See Figure 3.
9. Glue raised center panels to 1/8" plywood inserts (do not use nails). See Isometric, Sections A-A and B-B and Detail 1.
10. Nail and glue side panels to shelves N (see Note 5). Refer to Sections A-A and B-B for position. Check for squareness.
11. Attach face frame J, K, L and M to cabinet using 1 1/4" finish nails and glue. Refer to Isometric.
12. Round-over top edges of base boards Q and R (see Section A-A and B-B). Attach boards Q and R to cabinet using 1 1/4" finish nails and glue. Refer to Isometric and Sections A-A and B-B.
13. Attach boards O and P to side frames using 1 1/4" finish nails and glue. Refer to Section B-B.
14. Round-over bottom edges of boards V and W. Align top frame T and U and molding V and W and attach using 1 1/4" finish nails and glue. Refer to Isometric and Sections A-A and B-B.
15. Nail plywood S to back of unit. Refer to Sections B-B and C-C.
16. Round-over all four edges of boards Y, Z, CC and DD on the outside of the doors. Run a 3/8" x 3/8" rabbet around all four edges of boards Y, Z, CC and DD on the inside of the doors so that doors sit 3/8" into frames. Refer to Sections A-A and B-B and Detail 1.
17. Sand and stain the project.
18. Attach top lid and doors using brass ice box hardware.